

Your Current Vehicle: 2013 Chrysler Town & Country

Removal

REMOVAL

WARNING

To avoid serious or fatal injury on vehicles equipped with airbags, disable the Supplemental Restraint System (SRS) before attempting any steering wheel, steering column, airbag, seat belt tensioner, impact sensor or instrument panel component diagnosis or service. Disconnect and isolate the battery negative (ground) cable, then wait two minutes for the system capacitor to discharge before performing further diagnosis or service. This is the only sure way to disable the SRS. Failure to take the proper precautions could result in accidental airbag deployment.

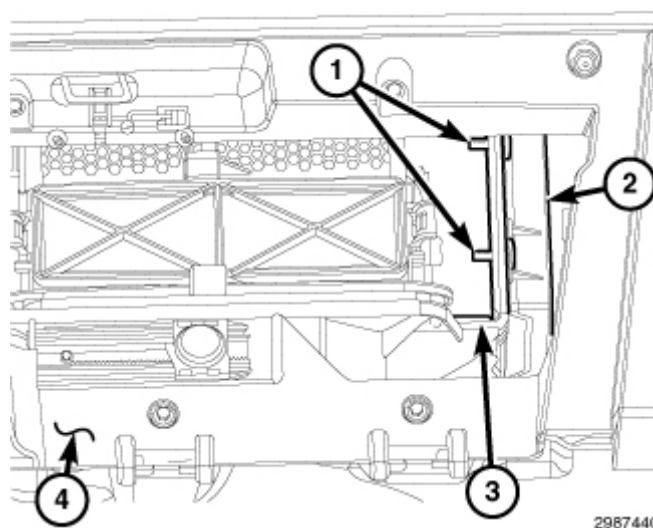

1. Disconnect and isolate the battery negative cable.
2. Remove the lower glove box from the instrument panel (4). (Refer to Body/Instrument Panel/GLOVE BOX, Instrument Panel - Removal)(Refer To List 1) (?a=0&t=59002).
3. Reach through the outboard side of the lower glove box opening to access and remove the two nuts that secure the two studs (1) of the Passive Entry Module (PEM) (2) bracket to the instrument panel hanger bracket (3) for the heater and air conditioner housing.
4. Still reaching through the outboard side of the lower glove box opening, reach around the outboard end of the heater and air conditioner housing to access and remove the one plastic push in fastener that secures the forward leg of the PEM bracket to the flange between the blower and recirculation housings.

5. Disconnect the two instrument panel wire harness connectors from the two connector receptacles of the PEM.

6. Remove the PEM from the vehicle.

Refer To List:

List 1

- 23 - Body / Instrument Panel / GLOVE BOX, Instrument Panel / Removal (?a=0&t=2773)
- 23 - Body / Instrument Panel, RHD / GLOVE BOX, Instrument Panel / Removal